

# CABLE STRIPPER 11KW

## ADDAX DEN15

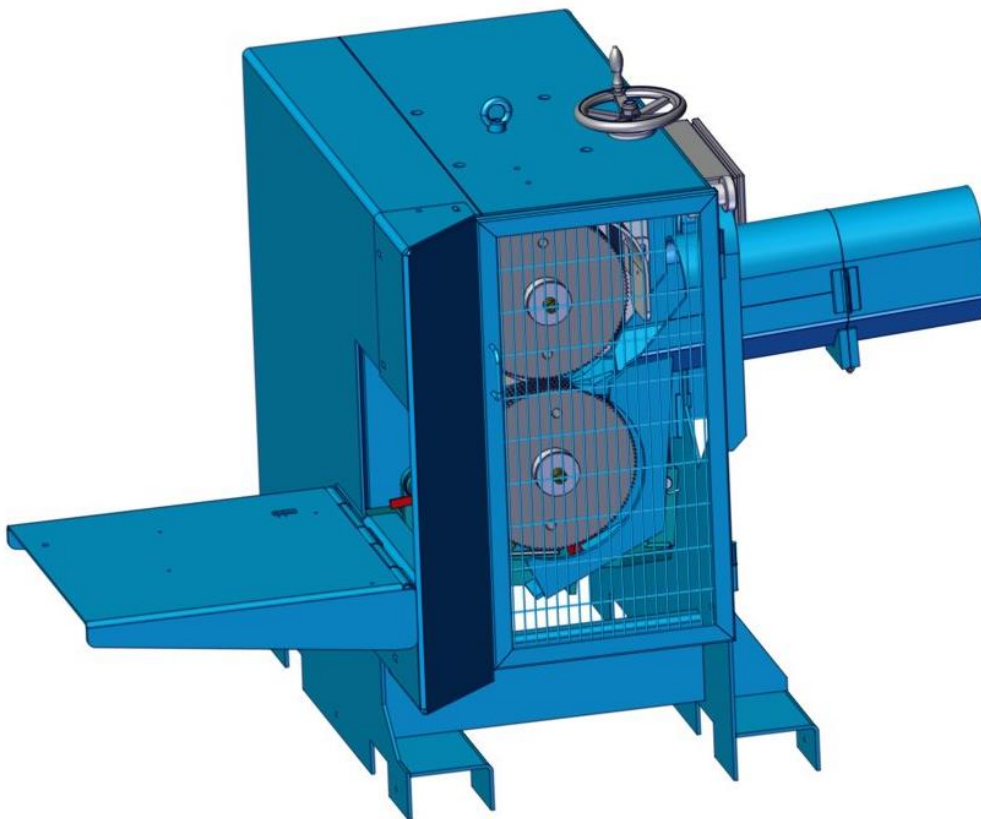

## Technical presentation

SECMI-ADDAX	ADDAX DEN15		Classe RCY	V01
		Date : 04 / 25th/2014	Auteur : CLS	1/4

### THE LARGE RANGE ADDAX CABLE STRIPPER

- Only one machine required to strip cables up to 160mm diameter.
- This Addax cable stripper has been designed to increase profitability in the recycling of the principal materials of electric cables :
  - Lead
  - Copper
  - Aluminium
- Inside, the machine is equipped with two generously proportioned motor- and gearbox units. All the mechanic parts run in oil. And the stripper is designed to give the maximum output.
- The toothed gripping wheels are quenched and tempered and designed for intensive service with armored cables.
- The knives can be re- sharpened and adjusted. They have also been heat-treated and can cut the main types of steel protections.
- The sturdy but flexible grip of the machine allows cables of slightly different diameter to be processed without modifying the settings which both saves time and makes the job easier.
- The electric control panel equipped with isolating switches, forward and reverse contacts, various fuses, thermal protection of the motor, complies with all the current safety rules.

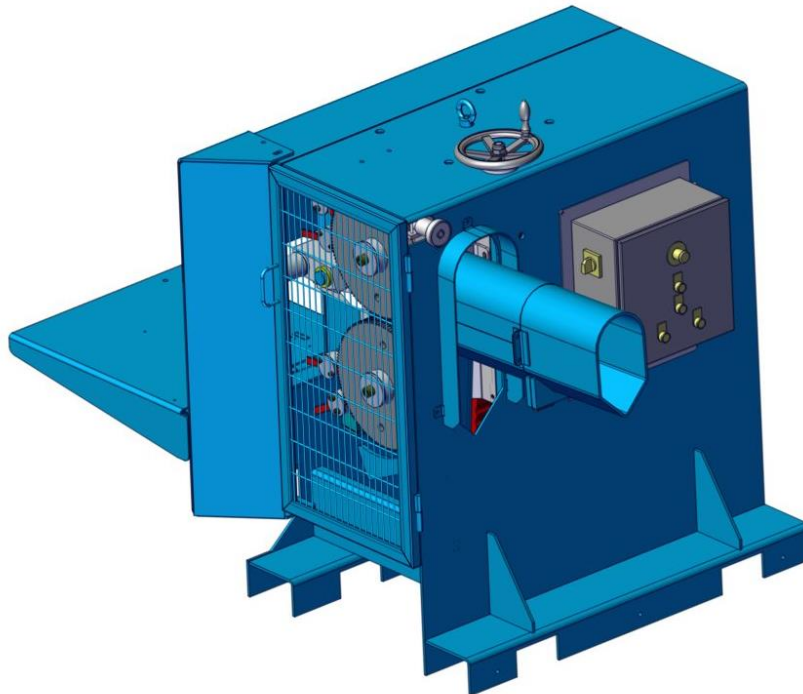

- CHARACTERISTICS \* :

- Capacity :  $\varnothing$  10 to 160 mm (3/8 to 6 1/4 ")
- Speed : 32 m/mm (105'/min)
- Power : 11 KW
- Length : 1480 mm
- Width : 1300 mm
- Height : 1560 mm
- Weight : 1300 kg

\* These data are given for information only and can be modified by the manufacturer.

